

規格 Specifications			型式 Modle	單位 Unit	CBR-1,200NC	CBR-1,500NC	CBR-1,800NC
加工能力 Capacity for drilling	加工直徑	Diameter for drilling	MM	4-32	4-32	4-32	
	加工長度	Max depth(Z Axis)	MM	1,200	1,500	1,800	
加工行程 Working feed	工作台左右行程 (X軸)	Table horizontal(X Axis)	MM	1,500	1,500	1,500	
	主軸台上下行程 (Y軸)	Table vertical(Y Axis)	MM	900	1,000	1,200	
	主軸前後行程 (Z軸)	Main spindle cross(Z Axis)	MM	1,200	1,500	1,800	
馬力 Horsepower	主軸馬力	Spindle motor	KW	7.5	7.5	7.5	
	工作台左右馬力	Table horizontal motor	KW	3.3	3.3	3.3	
	主軸台上下馬力	Head elevation motor	KW	3.3	3.3	3.3	
	主軸前後馬力	Feed motor	KW	2.1	2.1	2.1	
	高壓幫浦馬力	High pressure pump motor	KW	7.5	7.5	7.5	
	床台潤滑幫浦馬力	Table lubrication pump motor	KW	0.09 AC Motor	0.09 AC Motor	0.09 AC Motor	
加工進給速度 Table feed speed	工作台左右快送	Table rapid speed	MM/MIN	3,000	3,000	3,000	
	主軸上下前後快送	Rapid speed(X,Y Axis)	MM/MIN	5,000	5,000	5,000	
	主軸前後進給速度	Rapid speed(Z Axis)	MM/MIN	0-500	0-500	0-500	
工作台 Working table	工作台面積(LxW)	Size for working table(LxW)	MM	1,800x1,200	1,800x1,200	2,200x1,200	
	工作台載重	Table load weight	KGS	7,000	7,000	7,000	
冷卻系統 Coolant system	油壓箱容量	Tank capacity	L	1,200	1,200	1,200	
	高壓幫浦壓力	Pressure for high pressure pump	KG/CM <sup>2</sup>	105	105	105	
	高壓幫浦吐出量	Discharge qty. for high pressure pump	L/MIN	54	54	54	
	低壓幫浦吐出量	Discharge qty. for low pressure pump	L/MIN	90	90	90	
	工作台潤滑	Lubrication for working table	μ	75	75	75	
機械佔用面積	Machine size	MM	6,000x4,300	6,000x4,700	6,000x5,000		
機械重量	Machine weight	KGS	19,000	20,000	21,000		
總馬力	Total horsepower	KW	20	20	20		
控制系統	Control system		SIEMENS 802D				

## 機器尺寸 Machine size

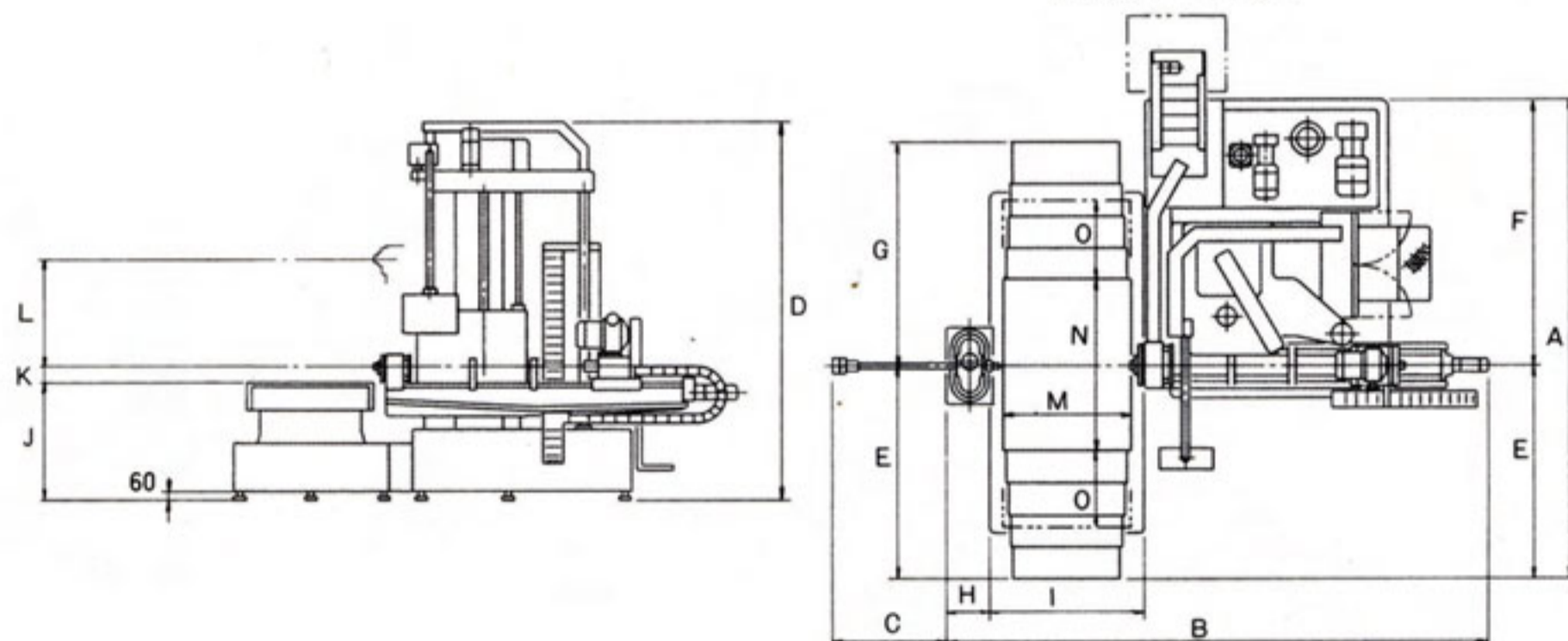

尺寸Size 型式Model	A	B	C	D	E	F	G	H	I	J	K	L	M	N	O
CBR-1200-NC	6000	4450	1000	3050	1980	2050	2400	450	1380	980	50	800	1200	1800	500
CBR-1500-NC	6000	4800	1100	3550	1980	2520	2400	450	1380	980	50	950	1200	1800	600
CBR-1800-NC	6000	5000	1100	3550	2400	2520	2400	650	1380	980	50	950	1200	2200	600