

# 床型立橫搪銑床 CS-VBM-5VHL

- CS-VBM-5VHL的X、Y和W軸使用鋼珠導螺桿及AC伺服馬達驅動，使進給可用快速、自動及手動等三種方法。
- 立主軸、鞍座及工作台使用油氣壓鎖緊裝置。
- 橫主軸轉速為40~1450RPM及12級變速。
- 主軸頭平衡配置，使頭部移動平滑及維持長時間之精度。
- X軸可增長為2000mm行程(選配)。

- The X, Y and W axes of CS-VBM-5VHL are equipped with ball screw and AC servo motor.
- There are three functions: Rapid & Jog & Manual feed.
- The vertical spindle head saddle and table are equipped with pneumatic hydraulic clamp device.
- The horizontal spindle speed is 40-1450 RPM and with 12 steps speed changes.
- A counter weight balance permits the head to travel smoothly and to retain its accuracy stability.
- The X-axis travel up to 2000mm is available on your request.

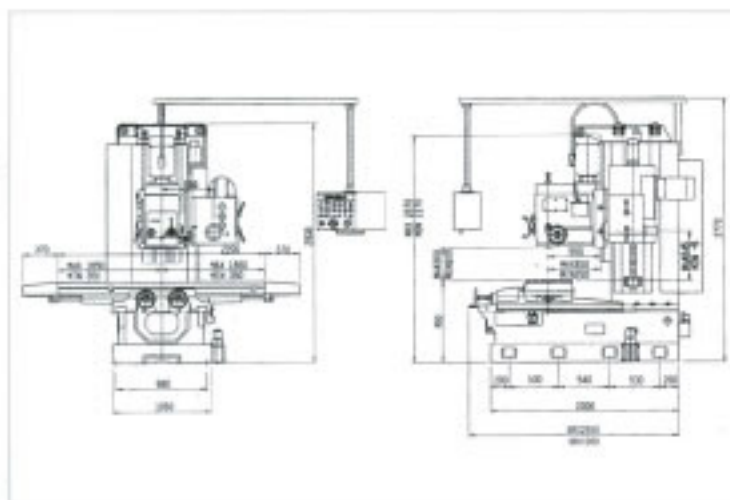

## SPECIFICATION 規格表

1 容量 CAPACITY			
工作台行程(左右)	Table travel(Longitudinal)	1,500(59')	mm(in)
工作台行程(前後)	Table travel(Cross)	600(23-5/8)	mm(in)
立主軸行程(上下)	Vertical spindle head travel(Vertical)	700(27-9/16)	mm(in)
橫主軸行程(上下)	Horizontal spindle head travel(Vertical)	650(25-9/16)	mm(in)
立主軸至工作台距離	Vertical spindle nose to table top	100-800(3-15/16-31-1/2)	mm(in)
立主軸中心至機身距離	Vertical spindle center to column front	550(21-5/8)	mm(in)
橫主軸中心與立主軸中心距離	Distance between Horizontal & vertical spindle center	550(21-5/8)	mm(in)
2 工作台 TABLE			
工作台尺寸	Table working area	2,200x500(86-5/8x19-11/16)	mm(in)
T型槽(寬x數x距)	T slot (WidthxNo.xPitch)	18x5x90(0.709x5x3-9/16)	mm(in)
工作台高度	Table top to floor	860(33-7/8)	mm(in)
3 主軸頭 SPINDLE HEAD			
主軸鼻端	Spindle nose	ISO R297 No.30	
立主軸轉速	Vertical spindle speeds	45-1,500(60HZ)	rpm
橫主軸轉速	Horizontal spindle speeds	45-1,450(60HZ)	rpm
立主軸級數	No. of Vertical spindle speed	12	steps
橫主軸級數	No. of Horizontal spindle speed	12	steps
進給速度(立主軸)	Feeds (vertical spindle)	0.05-0.2(0.002-0.008)	mm/rev(ipr)
4 進給速度 FEED / RAPID			
快速進給(左右和前後)	Rapid traverse(longitudinal & cross)	3,300(129-7/8)(60HZ)	mm/min(ipm)
橫主軸快速進給(上下)	Horizontal rapid traverse (Vertical)	3,800(150)(60HZ)	mm/min(ipm)
進給速度(左右和前後)	Feed rates(longitudinal & cross)	0-1,000(0-39-3/8)(60HZ)	mm/min(ipm)
橫主軸進給速度(上下)	Horizontal feed rates (Vertical)	0-1,000(0-39-3/8)(60HZ)	mm/min(ipm)
進給段數	Change of lead	無窮 infinitely variable	steps
5 電動機 MOTORS			
立主軸	Vertical spindle	AC 11(15)-4P	kW(HP)
橫主軸	Horizontal spindle	AC 5.5(7.5)-6P	kW(HP)
進給	Feed	SERVO MOTOR	
		X & Y axis: 3.5(4.7)	kW(HP)
		W axis: 0.85(1.14)	kW(HP)
潤滑	Lubrication	AC 3.5W-2P	
切削液	Cutting fluid	AC 0.15(1/8)-2P	kW(HP)
6 機械尺寸 MACHINE SIZE			
總高	Machine height	2,870(113)	mm(in)
佔地面積(左右x前後)	Floor space(longitudinal x cross)	4,440x2,550(174-7/8x100-3/8)	mm(in)
總重(約)	Net weight(Approx)	8,700(19,140)	kg(lb)
標準色	Standard color	灰色 Gray	

由於不斷的研究發展改善，機械設計及規格如有更改，恕不另行通知。  
All specification and designs are subject to change without notice.

### 標準附件 STANDARD ACCESSORIES

1. 切削液裝置	Cutting Fluid Device	1 unit
2. 調整工具	Tools And Box	1 set
3. 水平調整塊	Levelling Blocks	8 pcs
4. 水平調整螺栓及螺帽	Levelling Bolts And Nuts	8 sets
5. 拉桿	Draw Bar	1 pce

### 特殊附件 OPTIONAL ACCESSORIES

1. 數字讀頭裝置	Digital read out
2. 自動拉刀裝置	Power draw bar