

床型立式搪銑床 CS-VBM-3V

精準的工作台及鞍座

工作台及鞍座用強韌鑄鐵鑄造，滑動面的平面度，平行度及直角度均經慎重的摺合，無論強力重切削或精細加工均能保持精度。

TABLE AND SADDLE

The table and saddle are made of high-quality cast iron which has been carefully stress relieved. Way surfaces are hand scraped and finished.

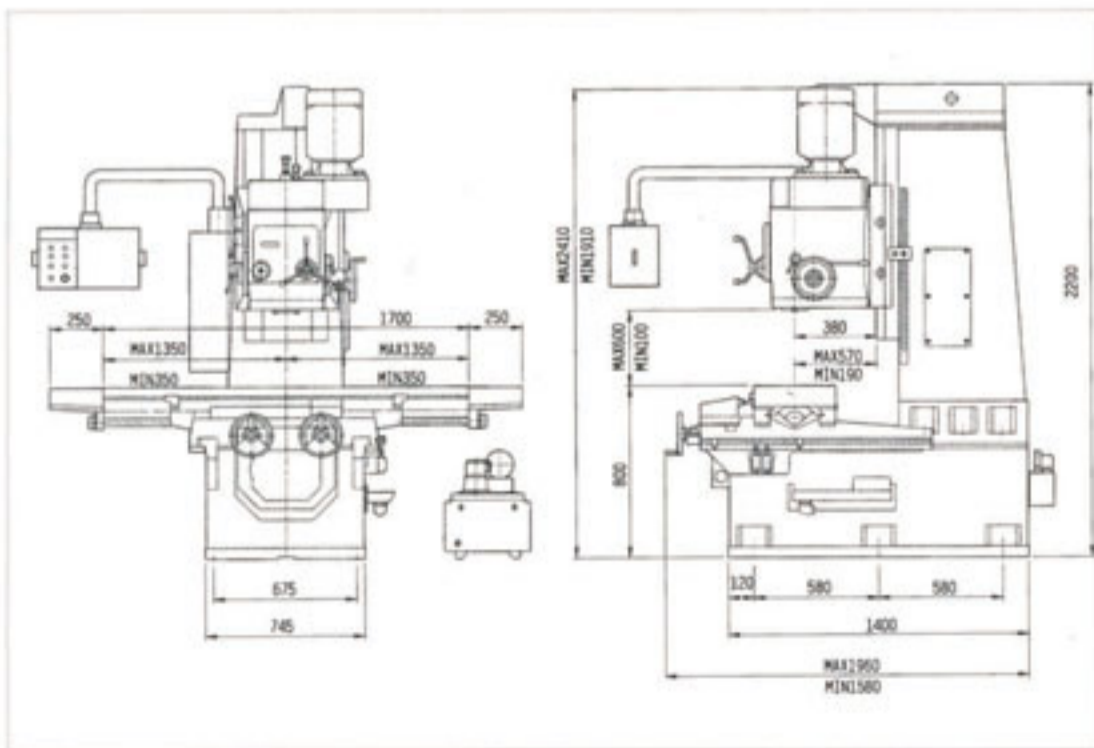

SPECIFICATION 規格表

1 容量 CAPACITY

工作台行程(左右)	Table travel(Longitudinal)	1,000(39-3/8)	mm(in)
工作台行程(前後)	Table travel(cross)	380(14-15/16)	mm(in)
立銑頭行程(上下)	Vertical spindle head travel(vertical)	500(19-11/16)	mm(in)
立主軸端至工作台面距離	Vertical spindle nose to table top	100-600(3-15/16~23-5/8)	mm(in)
立主軸中心至機身面距離	Vertical spindle center to column front	380(14-15/16)	mm(in)

2 工作台 TABLE

工作台面尺寸	Table working area	1,700x380(67x14-15/16)	mm(in)
T型槽(寬x數x距)	T slot (WidthNo.x Pitch)	18x5x70(0.709x5x2-3/4)	mm(in)
工作台面高度	Table top to floor	800(31-1/2)	mm(in)

3 主軸頭 SPINDLE HEAD

主軸鼻端	Spindle nose	ISO R297 No.50	
立主軸轉速	Vertical spindle speeds	45-1,500(60HZ)	rpm
立主軸段數	No. of Vertical spindle speed	12	steps
進給速度(立主軸)	Feeds (vertical spindle)	0.05-0.2(0.002-0.008)	mm/rev.(ipr)

4 進給速度 FEED / RAPID

快速進給(左右和前後)	Rapid traverse(longitudinal & cross)	2,880(113-3/8)(60HZ)	mm/min(ipm)
進給速度(左右和前後)	Feed rates(longitudinal & cross)	28-875(1-1/8~34-7/16)(60HZ)	mm/min(ipm)
進給段數	Change of feed	12	steps

5 電動機 MOTORS

立主軸	Vertical spindle	AC 5.5(7.5)-4P	kW(HP)
進給	Feed	AC 0.75(1)-4P	kW(HP)
潤滑	Lubrication	AC 3.5W-2P	
切削液	Cutting fluid	AC 0.1(1/8)-2P	kW(HP)

6 機械尺寸 MACHINE SIZE

總高	Machine height	2,410(94-7/8)	mm(in)
佔地面積(左右x前後)	Floor space(longitudinal x cross)	3,200x2,000(126x78-3/4)	mm(in)
總重(約)	Net weight(Approx)	4,000(8,800)	kg(lbs)
標準色	Standard color	灰色 Gray	

由於不斷的研究發展改進，機械設計及規格如有更改，恕不另行通知。
All specification and designs are subject to change without notice.

標準附件 STANDARD ACCESSORIES

1. 切削液裝置	Cutting Fluid Device	1 unit
2. 調整工具	Tools And Box	1 set
3. 水平調整塊	Levelling Blocks	6 pcs
4. 水平調整螺栓及螺帽	Levelling Bolts And Nuts	6 sets
5. 拉桿	Draw Bar	1 pce

特殊附件 OPTIONAL ACCESSORIES

1. 數字讀取裝置	Digital read out
2. 自動拉刀裝置	Power draw bar